

SYSTEMATIC QUALITY

# MarkLED/ MarkLED EXIT



Product information



## Introduction

Introduction



Page 3

Page 3

## MarkLED 4

Product/System

Technical data

Applications

Product range

Applications



Page 4

Pages 4-9



Page 5



Pages 6-7



Page 8



Page 9

## MarkLED EXIT

Product/System

Technical data

Applications

Product range

Applications



Page 10

Pages 10-15

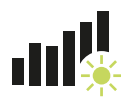

Page 11



Page 12-13



Page 14



Page 15

## Accessories

Control unit and remote control

Power supply

System components/mounting

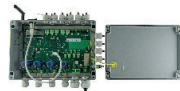

Page 16

Pages 16-19



Page 17

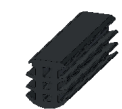

Pages 18-19

## LED guidance systems – for safe traffic routing



MarkLED 4



MarkLED EXIT

Our product line of optical guidance devices is applicable in tunnels, roundabouts or on the road in general.

We have detailed information, documentation, certificates for our system MarkLED which we would be appreciate to send if you are interested.

### Why optical guidance systems?

An optical guidance device improves recognition of lanes or obstacles, particularly during times of poor visibility (at night, fog, etc.) as well as vulnerable traffic areas such as tunnels, curves, roundabouts or traffic islands. The signals provide a very high degree of safety for traffic.

The system complies with current regulations (BAST Germany, FEDRO Switzerland e.g.), and are continous EMC-approved, which means, that the system functions with cables/wires and is non-inductive, so electromagnetic fields are excluded.

The wired systems are installed directly in the road surface. However, it is important that the installation area is not constantly driven over.

Our recess-mounted lamps are compatible with all GIFAS systems. They complement each other ideally and require the same system components, such as a control unit, feeder cable, etc.

All GIFAS systems can be dimmed across a continuous scale using the control unit or remote control.

### Your benefits at GIFAS

- EMC-approved, no inductive interference
- quick and easy installation
- latest LED technology, very low power consumption
- vandal-proof, reinforced synthetic material/V4A Investment casting
- dimmable by control unit
- interoperable with all LED guidance systems
- modular construction, low-maintenance
- often set in systems in different applications
- thereby high product- and application know-how

### Our services

- many years of know-how, experienced Project Manager
- individual advice, also on site
- large standard range, individual solutions possible
- expert advice on installation and bringing into service
- creating CAD documents, voltage drop calculations and tunnel disposals
- own service team with professional equipment and many years of know-how





The MarkLED is a cable-guiding system with current carried through direct connections. This allows us to reach a very high efficiency factor (>80%) and to remain within the limits for electromagnetic compatibility (EMC). With the state-of-the-art LED technology, power consumption is so low that the desired line lengths can be usually realised without intermediate supply. The power consumption is extremely low because of the high energy efficiency. With those technical features we comply with regulations and expectation from public institutions and departments of international road engineering.

### The upper part – the MarkLED light module

The new top part is executed in an attractive and elegant form with a housing made of special transparent plastic. The outer surface is nano coated and antistatic for high dirt repellency. The electronics are installed from below and sealed with a neutral, white sealing compound. The brightness of the individual modes, such as dimming, blinking and flashing, are easily adjustable via the control units associated with the system and can also be influenced from the tunnel control centre or by overriding pulses.

### The lower part – the current collector

The «core» of this system is the current collector. It transfers the power from the system cable to the light module and offers it a fixed base for mounting. The cable need not be cut and therefore, continues to be fail-safe. The light module comes preassembled on the current collector (fast and safe installation on site).

1. Placement of the system cable in prepared groove
2. Power transfer from the system cable to the light module
3. Mounting base for light module

### The system cable

For the LED guidance systems you need a system cable as a feed line of every module.

### Control units

The new 4-channel control unit is used to control the GIFAS guidance systems. It can be integrated into existing control cabinets or also as a «stand alone» module.

### Accessories

The diverse range of accessories allows different areas of application and fulfills complex customer requirements.

### Functionality

The guidance systems have a wide voltage range between 16-48VDC. This allows to realise very long line distances. In addition, all systems are tested to meet IP68 protection.

Thanks to the modular design, the individual components can be replaced quickly in case of service.

### Product documentation

#### Installation instructions

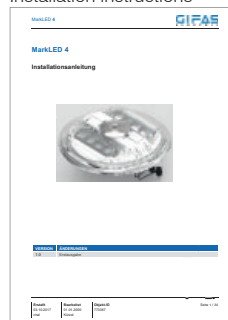

#### Reference list



#### Test reports

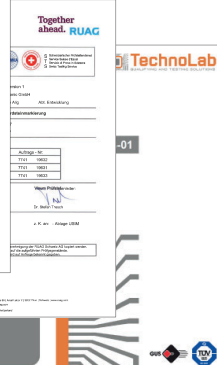





## Technical data

Single or double-sided with 4 LEDs each

Light colour:	white ~5'600K
Light intensity:	65 cd
Operating life LED:	L90/B10 100'000h
Protection category:	IP68/IP69
Protection class:	III
Impact protection rating:	IK10
Operating voltage:	24 VDC (range 16-48VDC)
Power consumption:	30 mA (double-sided LED white) 80 mA (double-sided LED colored)
Diameter:	110 mm
Height	
– without current collector:	18 mm
– with current collector:	20 mm
Upper part:	polyketone, colourless, nano coated, dirt-repellent
Lower section:	polyamide 12 black, glass fiber reinforced
System cable:	system cable bipolar 2x2.5 mm <sup>2</sup>
Temperature resistance:	-40°C to +55°C
Axle load:	to 5t (slow traffic with air-filled tyres)

Certificates, reference lists on request.

## One-components MarkLED 4

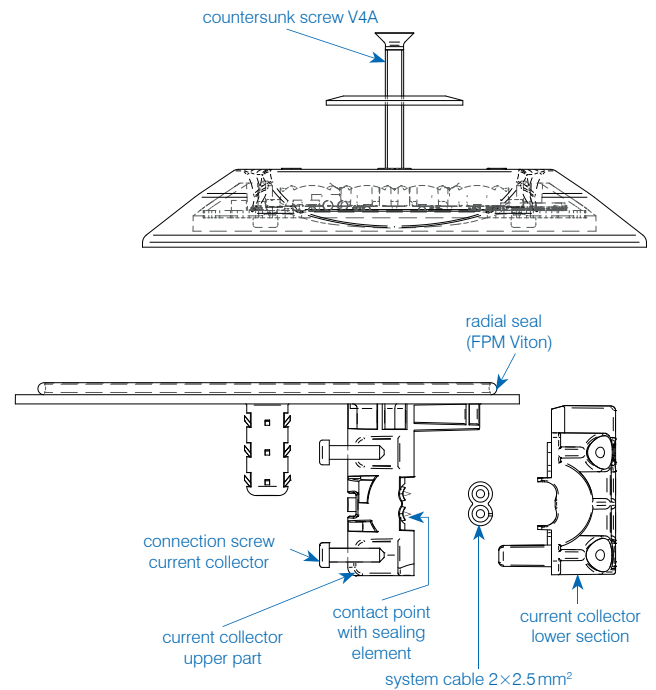

## Scheme light emission

MarkLED the system meets the regulations of the Federal Road Authority (e.g. BAST-Germany, FEDRO Switzerland).

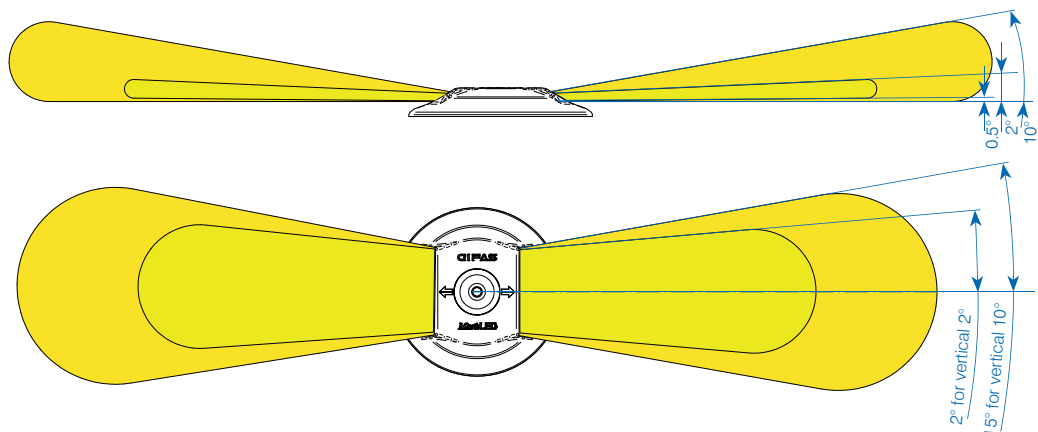

## Example 1 – wired

By default, the MarkLEDs are connected with current collector in a milled groove in the shoulder. If this is not possible, a conventional strand cabling with junction boxes/sleeves can be realised. Here, a strand cabling with FE180 cable is installed and connected to a box/sleeve.

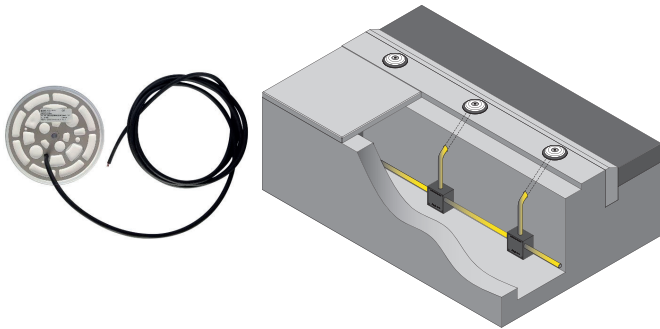

Tunnel Schaffhausen

## Example 2 – New Jersey profile

If the MarkLED has to be mounted for example on a New Jersey profile then there should be made a cross drill through the profile. On the backside a junction box can be set or inserted directly in a existing cable tray.

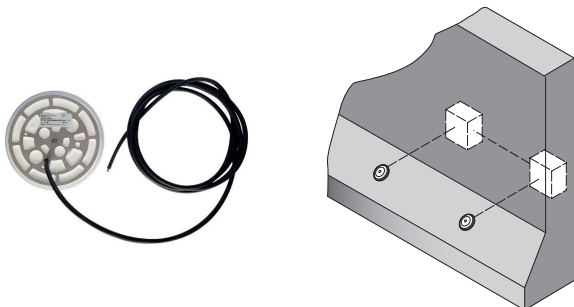

Tunnel Stephanshorn St. Gall

## Example 3 – recessed-mounted

With the recessed-mounted box for MarkLED we can offer a robust and easy solution for a recessed installation of MarkLED. On both sides, hose connection (M25) are prepared for the connection of a protective hose.

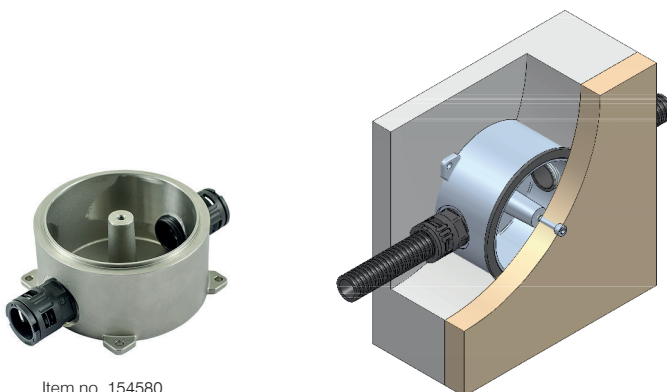

Item no. 154580

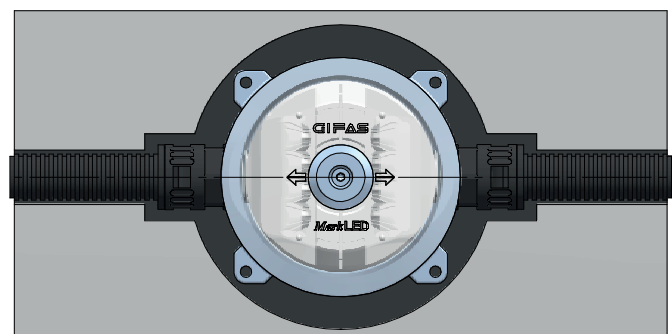
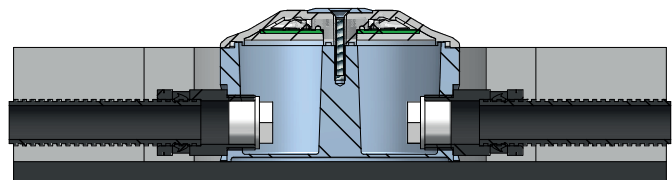



## Example 4 – surface-mounted (casing V4A)

A further possibility to mount the MarkLED is with surface-mounted solution. Here, the MarkLED is screwed onto a surface-mounted box, wherein the MarkLED has no current collector, but a direct outlet, which is connected to the feed line in the housing.



Item no. 152744

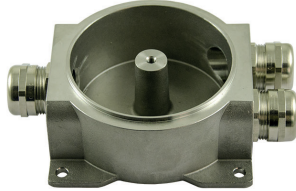

Item no. 144534



Tunnel Limfjord Denmark

## Example 5 – surface-mounted (plastic adapter)

Simple and secure assembly of the MarkLED modules on the shoulder/wall by means of the surface mounted plastic adapter.



Surface-mounted adapter MarkLED 4  
made off PA 6 BK40



Surface-mounted adapter with  
guard plate (Item no. 208653)



Biel Bözingerfeld



Bypass Bütschwil

## Complete product module

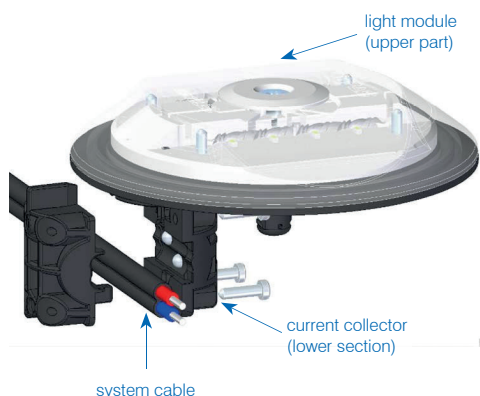

## System cable light

The system cable MarkLED is a halogen-free EPR/EPR cable with tinned copper strands, high temperature resistance, bonding between the insulations of strands and the cable coating to increase water tightness.

### Technical data

Material properties:	halogen-free, no toxic and corrosive gases
Fire behavior:	low smoke emission, flame-retardant, no fire spread, low fire load
Strand colors MarkLED:	red, dark blue
Nominal section:	2.5 mm <sup>2</sup>
Exterior dimensions:	9.6 mm × 5.25 mm
Weight (kg/km):	approx. 80 kg/km
Cu-Number (kg/m):	48 kg/km (48 g/m)
Temporary temperature resistance:	<10 s: 200 °C
Fire class:	B2ca-s1-d1-a1

Item no.	Designation
115788	System cable light black – copper tinned flat cable EPR/EPR, 2×2.5 mm <sup>2</sup>
148912	System cable light red – copper tinned, flat cable EPR/EPR, 2×2.5 mm <sup>2</sup>
148913	System cable light blue – copper tinned, flat cable EPR/EPR, 2×2.5 mm <sup>2</sup>

## Drilling jig MarkLED 4

Drilling jig for mounting hole Ø9mm and installation hole for current collector pin Ø40mm.



Item no.	Designation
860599	Drilling jig MarkLED 4

## Product range MarkLED 4

Item no.	Designation
860247	MarkLED 4 light module with current collector 30 mA/double-sided 4×white, 5'600 K
860900	MarkLED 4 light module with current collector 30 mA/double-sided 4×white, 5'600 K, BAST switchable via dimming levels
860560	MarkLED 4 light module with current collector 80 mA/double-sided 4×green, 525 nm
860561	MarkLED 4 light module with current collector 60 mA/4×white, 5'600 K/4×red, 625 nm
860562	MarkLED 4 light module with current collector 80 mA/double-sided 4×yellow, 595 nm
860563	MarkLED 4 light module with current collector 80 mA/double-sided 4×blue, 475 nm
860567	MarkLED 4 light module with strands 2×0.5 mm <sup>2</sup> , 20 cm 30 mA/double-sided 4×white, 5'600 K for surface mounted applications
860901	MarkLED 4 light module with strands 2×0.5 mm <sup>2</sup> , 20 cm 30 mA/double-sided 4×white, 5'600 K, BAST switchable via dimming levels
860598	MarkLED 4 light module with cable 2×0.5 mm <sup>2</sup> , 2m, with V4A mounting plate, 30 mA/double-sided 4×white, 5'600 K
860246	MarkLED 4 light module with 2 NTQ plugs 30 mA/double-sided 4×white, 5'600 K
860899	MarkLED 4 light module, connectable NTQ/30 mA double-sided 4×white 5'600 K
860245	MarkLED 4 current collector
152744	MarkLED casing V4A, 110×110×29 mm 2 KV M16×1.5 for cable Ø5-10 mm
144534	MarkLED casing V4A, 115×115×46 mm 3 KV M25×1.5 for cable Ø9-16 mm
154580	MarkLED casing V4A, 110×110×55 mm 2×M25 hose connection
860724	Surface mounted MarkLED adapter, PA 6 BK40 white incl. accessoires (VE=5 piece) without cable gland
860725	Surface mounted MarkLED adapter, PA 6 BK40 white incl. accessoires (VE=5 piece) with 1×cable gland M16×1.5
860726	Surface mounted MarkLED adapter, PA 6 BK40 white incl. accessoires (VE=5 piece) with 2×cable gland M16×1.5

Other versions on request





Tunnel Schaffhausen



Bypass Bütschwil



Tunnel Schaffhausen



Garage Zermatten Chalais



Bypass Biel-Bözingenfeld



Tunnel lighting Nordoyatunnel Färöer

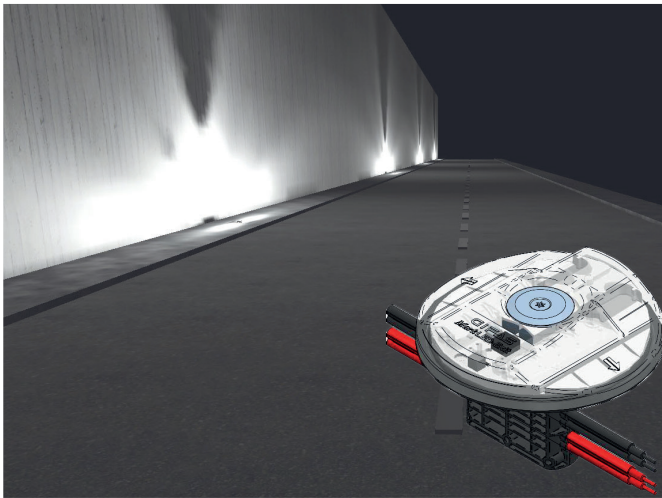

The MarkLED EXIT combines two tunnel safety lighting systems. It is a combination of guidance and escape route light, and the road studs (optical guidance system) are typically installed at distances of 12.5m and 25m respectively. The MarkLED EXIT is therefore equipped with two separate lighting areas with two different characteristics, usually installed at a distance of 25m, using the same connection system, which in combination makes the system very economical.

In normal operation, only the part of the marker light (optical guidance system) is in operation. During an incident, the EXIT part is switched on so that the escape route is sufficiently lit. The MarkLED EXIT also has a wide voltage range of 18-48VDC. This allows lengths over 500m.

### The light module, MarkLED EXIT

The two lighting systems of the MarkLED EXIT are housed in the same size as the normal MarkLED 4. With the MarkLED 4, the MarkLED EXIT also shares the technology for the marker light (optical guidance system). The exact data of the marker light can be found on pages 4-7. The EXIT part has 4 high-power LEDs, emitting on both sides. They come with a special optical coating for safe lighting of escape routes. Optionally, the MarkLED EXIT can be installed in the shoulder or on the wall.

### The current collector

It transfers the power from the system cable to the light module and offers it a fixed base for mounting.

The cable need not be cut and therefore, continues to be fail-safe. The light module comes preassembled on the current collector (fast and safe installation on site).

1. Placement of the system cable in prepared groove
2. Power transfer from the system cable to the light module
3. Mounting base for light module
4. Integrated replaceable fuse inserts (micro-fuse 20×5 mm) for safety separation in case of fire.

The system MarkLED EXIT with functional maintenance E30/E60, tested according DIN EN 1363-1:2012-10 and based on DIN 4102-12.

### The system cable

The light system is connected by a double-guided system cable with a cross section of 2×2.5mm<sup>2</sup>. This cable is embedded in a groove in the shoulder in the case of floor mounting.

### Control units

The 4-channel control unit is used to control the GIFAS guidance systems. It can be integrated into existing control cabinets or also as a «stand alone» module.

The EXIT part can be powered directly via its own power supply, as it is operated with full brightness in the case of an incident and a control makes little sense.

### Accessories

The diverse range of accessories allows different areas of application and fulfills complex customer requirements.

### Functionality

The MarkLED EXIT is a system that can be used as a guidance in the tunnel as well as the actual escape route lighting. Corresponding sample installations have been created and tested in cooperation with FEDRO. The application must be checked carefully for each project, depending on the structural conditions.

### Product documentation

Installation instructions

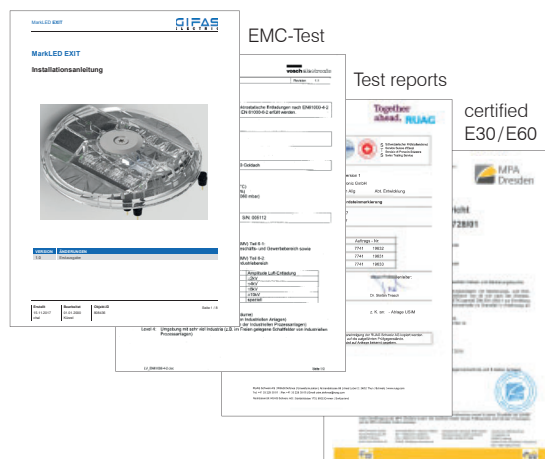



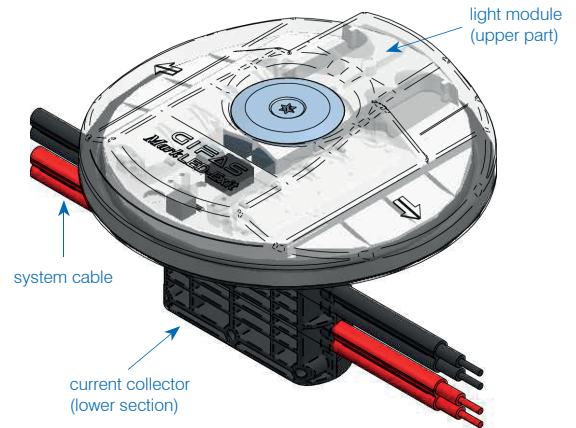

## Technical data

Double-sided with four white LEDs (5'600K) as optical guidance system in direction of traffic and in opposite direction. Escape route lighting turned against the wall with four white LEDs (5'900K).

### Light colour:

- optical guidance system 5'600K
- escape route lighting 5'900K

### Light intensity:

- optical guidance system 65 cd
- escape route lighting 1390 cd

### Operating life LED:

- optical guidance system L90/B10 100'000h
- escape route lighting min. 10'000h

### Protection category:

IP68/IP69

### Protection class:

III

### Impact protection rating:

IK10

### Operating voltage:

48VDC (18-48VDC, protected against polarity reversal)

### Power consumption:

- optical guidance system 30 mA (double-sided LED white)
- escape route lighting 80 mA (double-sided LED colored)

### Diameter:

110 mm

### Upper part:

polycarbonate, colourless, nano coated

### Lower section:

polyketone black, glass fiber reinforced

### System cable:

2x system cable bipolar  
2x 2.5 mm<sup>2</sup>

### Height above carriageway level:

21.5 mm

### Temperature resistance:

-40°C to +55°C

### Axle load:

< 5t (slow traffic with air-filled tyres)



Certificates, reference lists on request.

## One-components MarkLED EXIT

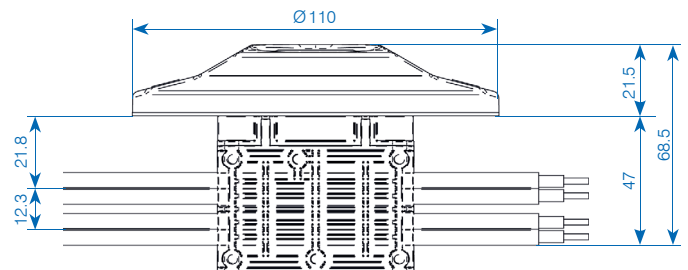
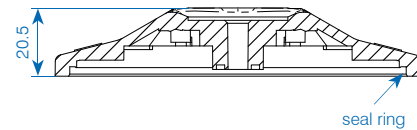

## Scheme light emission

Optical guidance system

(Light emission in the direction of traffic)

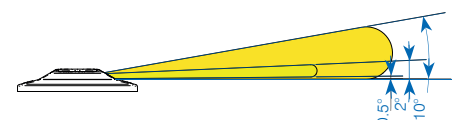
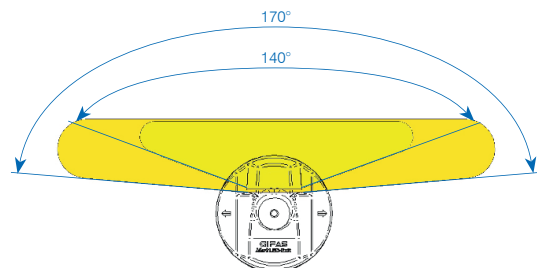
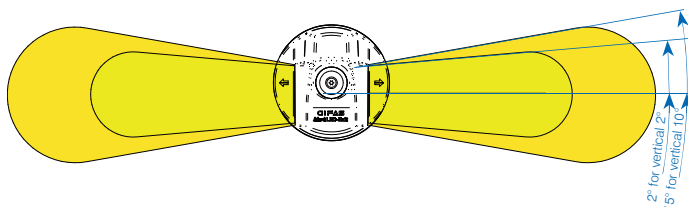

## MarkLED EXIT used for escape route lighting

In the FEDRO 13015 guideline, the function of the escape route lights is defined as follows: In the case of an incident, it must be ensured that the escape route in the traffic area is sufficiently visually perceived. A separate fire escape route lighting is not required if this function can be taken over by the optical guidance system.

With this pioneering new development of the MarkLED EXIT, which combines the optical guidance system and the escape route lighting in one, a new dimension of economy is achieved.

In this execution, a second light source with focused radiation is integrated into the proven guidance system. This is only activated in case of an incident and immediately reaches its full brightness.

The MarkLED EXIT modules are equipped with cold conductor monitoring (function monitoring of the EXIT area possible with the escape route lighting off).

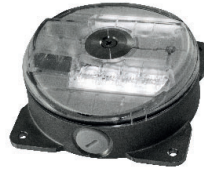

*Example: MarkLED EXIT on surface/recessed-mounted housing in standard mode  
Standard= optical guidance system*



*Example: MarkLED EXIT on surface/recessed-mounted housing in emergency event mode  
Emergency= escape route lighting switched on*

### Example 1: Mounted on the floor

The luminaire is installed with the Exit element in the direction of the wall when assembling the MarkLED Exit on the shoulder (floor of the escape route). Part of the light is projected directly on the escape route. A large part of the light is also reflected onto the shoulder via the wall. This guarantees that the escape route is adequately illuminated.



### Example 2: Mounted on the tunnel wall

The luminaire is installed with the Exit element in the direction of the floor when assembling the MarkLED Exit on the wall. A large part of the light is projected directly on the escape route. Part of the light is also reflected onto the shoulder via the wall. This guarantees that the escape route is adequately illuminated.





## Example 4 – surface-mounted (casing V4A)

A further possibility to mount the MarkLED is with surface-mounted solution. Here, the MarkLED is screwed onto a surface-mounted box, wherein the MarkLED has no current collector, but a direct outlet, which is connected to the feed line in the housing.



Item no. 152744

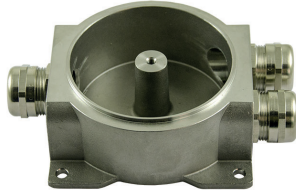

Item no. 144534



Gullbergstunneln Schweden

## Example 5 – surface-mounted (adaptateur matière synthétique)

Simple and secure assembly of the MarkLED modules on the shoulder / wall by means of the surface mounted plastic adapter.



Surface-mounted adapter MarkLED EXIT made off PA 6 BK40



Surface-mounted adapter with guard plate (Item no. 208653)



Surface-mounted adapter MarkLED EXIT



Tunnel Thun

## Complete product module

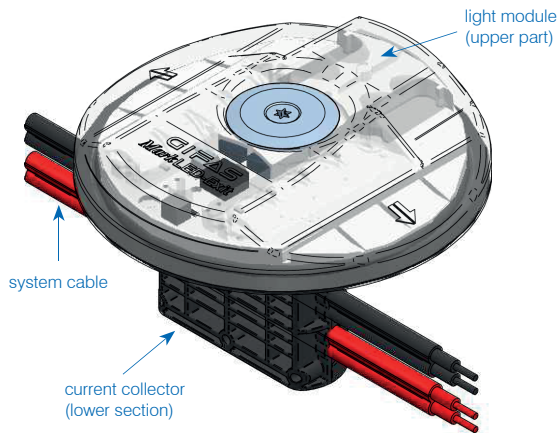

## System cable

The system cable MarkLED is a halogen-free EPR/EPR cable with tinned copper strands, high temperature resistance, bonding between the insulations of strands and the cable coating to increase water tightness.

## Technical data

Material properties:	halogen-free, no toxic and corrosive gases
Fire behavior:	low smoke emission, flame-retardant, no fire spread, low fire load
Strand colors MarkLED:	red, dark blue
Nominal section:	2.5 mm <sup>2</sup>
Exterior dimensions:	9.6 mm × 5.25 mm
Weight (kg/km):	approx. 80 kg/km
Cu-Number (kg/m):	48 kg/km (48 g/m)
Fire load (kwh/m):	approx. 1'280 kJ/m
Temporary temperature resistance:	< 10 s: 200° C
Fire class:	B2ca-s1-d1-a1

Item no.	Designation
115788	System cable light black – copper tinned, flat cable EPR/EPR, 2×2.5 mm <sup>2</sup>
148912	System cable light red – copper tinned, flat cable EPR/EPR, 2×2.5 mm <sup>2</sup>
231694	Gifasafety cable CPR Cca s1-d1-a1 2×2,5mm <sup>2</sup> strands tin-plated (red, black) ø8,7 mm +/-0,3 for system MarkLED/incl. rodent guard
236892	Gifasafety cable CPR B2ca s1-d1-a1 4×2,5mm <sup>2</sup> rigid (red, black, blue, white) ø12,5 mm +/-0,5mm for system MarkLED/incl. rodent guard

## Product range MarkLED EXIT

Item no.	Designation
860327	MarkLED EXIT light module with current collector Guidance: 30 mA/double-sided 4×white, 5'600 K Emergency: 180 mA@48VDC/4×white, 5'900 K
860467	MarkLED EXIT light module with current collector Guidance: 80 mA/double-sided 4×yellow, 595 nm Emergency: 180 mA@48VDC/4×white, 5'900 K
860597	MarkLED EXIT light module with current collector Guidance: 60 mA/4×white, 5'600 K/4×red, 625nm Emergency: 180 mA@48VDC/4×white, 5'900 K
860564	MarkLED EXIT light module with strands 4×0.25mm <sup>2</sup> , 20 cm Guidance: 30 mA/double-sided 4×white, 5'600 K Emergency: 180 mA@48VDC/4×white, 5'900 K
860604	MarkLED EXIT light module with cable 4×0.25 mm <sup>2</sup> , 2 m, with V4A mounting plate, Guidance: 30 mA/double-sided 4×white, 5'600 K Emergency: 180 mA@48VDC/4×white, 5'900 K
860326	MarkLED EXIT light module with 4 NTQ plugs Guidance: 30 mA/double-sided 4×white, 5'600 K Emergency: 180 mA@48VDC/4×white, 5'900 K
860325	MarkLED EXIT current collector
860890	Surface mounted MarkLED EXIT adapter, PA 6 BK40 white incl. accessoires (VE=5 piece) without cable gland
860891	Surface mounted MarkLED EXIT adapter, PA 6 BK40 white incl. accessoires (VE=5 piece) with 1×cable gland M16×1.5
860892	Surface mounted MarkLED EXIT adapter, PA 6 BK40 white incl. accessoires (VE=5 piece) with 2×cable gland M16×1.5

Other versions on request





Mariefholmstunnel Göteborg Schweden



Tunnel Thun



Tunnel Thun



Tunnel Thun



Mariefholmstunnel Göteborg Schweden



Tunnel Thun

## 4-channel control unit

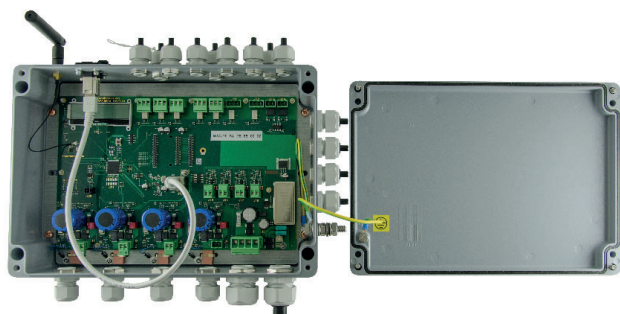

The control unit for all GIFAS systems is designed for 4 output lines. Each channel can be loaded with up to 10A.

- **Supply:** a 230VAC/24-48VDC power supply device with a nominal output current of 40A is installed upstream from the control unit.
- **Error messages:** each channel has a relay with SPDT (potential free) assigned to the signaling of error messages.
- **External blinking contacts:** by default, two external flashing signals (24-60VDC) can be connected and transferred to the outgoing lines (synchronisation with flashing signal).
- **Operating mode:** the control unit has 8 or 31 different modes of operation.
- **Failure rate:** by failure rate detection, the lights can be tested for their functionality. The control unit measures the total power consumption of the respective channel. If the power consumption drops to a preset value, the fault message can be detected via a changeover contact (potential-free).
- **Functions:** one of the following functions can be assigned to each channel in each mode:
  - continuous lighting: 100%
  - dimming: adjustable from 1-99%
  - flash: adjustable from 0.1-9.9Hz
  - lightning: adjustable from 1-99ms
  - running light: running light direction, dimming 1-99%, Light duty cycle 100ms-10sek, delay in lighting 100ms-10sek, switch-on delay 0-999sek, duty cycle 0-999sek
  - off
- **Programming:** the control unit can be optionally parametrised and read out via the web interface or the optionally available radio programming unit.
  - Web interface: if the control unit is connected to the network via RJ45 Cat. 6a, all parameters can be set and read out via a web browser.
  - Radio programming unit: the parameters can also be set by the radio programming unit.

### Technical data

Protection category:	IP65
Rated power max.:	1'920 VA
Input voltage:	18-48VDC
Supply current:	40A, 4 channels à 10A
Power supply:	external
Dimensions:	330×230×110mm

## Remote control to 4-channel control unit



Programming device with menu guide for set-up, programming and status recognition of the control unit. Communication with the control unit occurs through radio.

All necessary functions can be set up and assigned through the menu structure. No special knowledge is required to operate it. The connection between the control unit and the programming device is bi-directional, i.e. the current settings can be transferred from one to the other.

The buttons «↑», «↓», «☒» and «✓» are used to navigate the system. The range is approx. 3m.

The menu is available in four languages: German, English, French and Italian.

### Technical data

Material:	ABS
Protection category:	IP40
Protection class:	III
Radio frequency:	2.4-2.525 GHz
Operating voltage:	4.5VDC, 3 batteries AAA
Life of battery:	> 1 year in standby mode
Dimensions (WxHxD):	73×140×32 mm
Colour:	graphite grey similar to RAL 7024

Item no.	Designation
860594	4-channel control unit in cast aluminium housing, IP65, 18-48VDC/4×10A, excl. power supply

Item no.	Designation
860460	Remote control to 4-channel control unit



## Power supply to 4-channel control unit



A 230VAC/24/48VDC power supply is installed upstream from the 4-channel control unit. The power supply is equipped with integrated protection against overloading and short-circuiting, with automatic or manual reset.

The power supply conforms to CEE regulations and also has UL and/or CSA approval.

### Technical data

Protection category:	IP20 (IP42 with additional cover)
Protection class:	I
Input voltage:	230 VAC (range 100-240 VAC)
Output voltage:	24/48VDC
Output current:	10/20 A
Connections primary:	screw terminals 4 mm <sup>2</sup>
Connections secondary:	screw terminals 4 mm <sup>2</sup>
Status display:	LED green
Installation:	quick fastening for DIN rail 35 mm
Dimensions (W×H×D):	different, see designation below

A detailed datasheet on the power pack is available on request

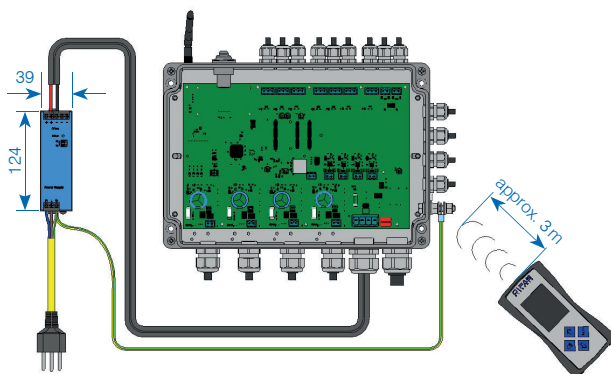

Item no.	Designation
163193	Power supply 230 VAC/24VDC -10A/240 W 39×124×117 mm
136629	Power supply 230 VAC/24VDC -20A/480 W 65×124×127 mm
202595	Power supply 230VAC/48VDC - 10A/480 W 48×124×127 mm
180867	Power supply 230 VAC/48VDC -20A/960 W 125×124×127 mm

Other versions on request

## Cold conductor monitoring



The cold conductor monitoring is used for detecting defective installations or lights that are not connected. The monitoring is automatically activated as soon as the lights are switched off.

- **Feeding:** a power supply 230 VAC/18-48VDC with a rated output current of max. 10 A is connected upstream of the cold conductor monitoring. The level of the output voltage of the power pack depends on the marking light used in this case.
- **Fault signal:** the cold conductor monitoring has two relays with change-over contact (potential-free) to signal fault messages for voltage interruption (for example, failure of the power supply unit) and exceeding of the failure rate (for example defect in the control unit installation).
- **Functions:** in every cold conductor monitoring, the threshold for the max. failure rate detection can be set individually in percentage. The adjustment range is 10-70% and can be adjusted in 10% increments.
- **Programming:** programming is done directly via the programming buttons on the control board or via the 4-channel control unit.

### Technical data

Protection category:	IP66
Rated power max.:	480 VA
Input voltage:	18-48VDC
Supply current:	10 A
Power supply:	external

Item no.	Designation
860603	Cold conductor monitoring in cast aluminium housing, IP65, 18-48VDC, 10 A, excl. power supply

## Fire-proof junction box

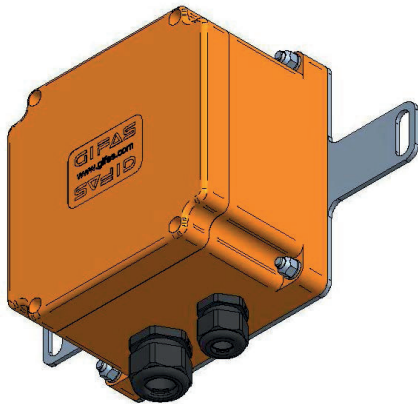

The safety cable must be connected from control center to the GIFAS system cable when connecting the signal units to the infrastructure. A special junction box is required for these connections. This can be installed in the cable trunks in the tunnel shoulder or at another suitable point. An E30/E60 junction box is usually required for this application. The size of junction box depends on the feed-in cable used as well as the number of outlets.

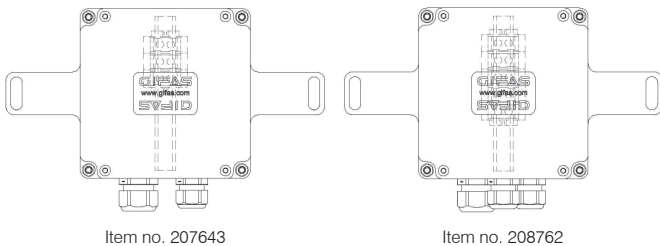

Item no.	Designation
207643	Junction box FE180/E30 type 1616 orange polyester fibre, IP66/68, 3×6.0mm <sup>2</sup> , 1×M20, 1×M25, incl. mounting plate
208762	Junction box FE180/E30 type 1616 orange polyester fibre, IP66/68, 5×6.0mm <sup>2</sup> , 2×M20, 1×M25, incl. mounting plate

## Installation material

### Protective hose

Depending on the type of installation, the system cable can also be conducted in an installation tube.



Item no.	Designation
035976	Installation tube Ø25/19 mm, fluted, flame-retardant, highly flexible, grey (selling unit 100m)
128266	Corrugated hose Ø21.2/16.5 mm, PA 6 flexible, black (selling unit 50m)

## Joint profile

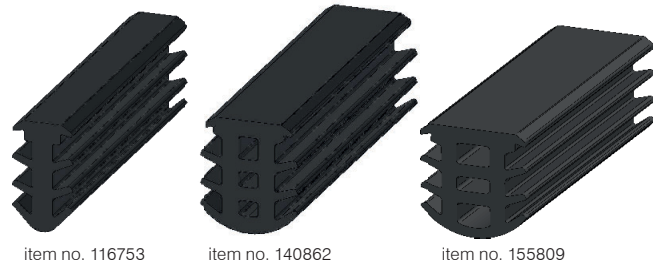

The milled groove of the optical guidance system must be sealed against environmental conditions. A simple and low-cost solution is to use the halogen-free GIFAS joint profile made of EPDM. This is inserted in the slot. It is self-locking and available in three different widths. A stable and smooth slot with slot widths of 6 -16 mm is the prerequisite for use.

### Technical data

Material properties: halogen-free, no corrosive and toxic gases  
 Shore hardness A: 70° ±5%  
 Special weight: 1.23kg/l  
 Elongation at break: 237% DIN 53504  
 Breaking stress: 11.2MPa DIN 53504

Item no. 116753  
 Exterior dimensions: 9.3 mm×17.1 mm  
 Groove width: 6 -8 mm  
 Nominal section: 89mm<sup>2</sup>  
 Weight: 109kg/km

Item no. 140862  
 Exterior dimensions: 14.5 mm×17.1 mm  
 Groove width: 10 -12 mm  
 Nominal section: 146mm<sup>2</sup>  
 Weight: 177 kg/km

Item no. 155809  
 Exterior dimensions: 17.35 mm×17.5 mm  
 Groove width: 14 -16 mm  
 Nominal section: 171 mm<sup>2</sup>  
 Weight: 254 kg/km

Item no.	Designation
116753	Joint profile EPDM 70° Shore for groove 6 -8mm, 9,3×17.1 mm, black
140862	Joint profile EPDM 70° Shore for groove 10 -12mm, 14,5×17.1 mm, black
155809	Joint profile EPDM 70° Shore for groove 14 -16 mm, 17,35×17.5 mm, black

## Sealing compound



The recommended sealing compound is heated to 160°–180°C while being constantly mixed. The compound is applied using a spouted container or grouting lance. Excess compound must be removed by scraping once it has fully cooled.

### Technical Data

Colour:	black
Form of delivery:	1 box with 24 cubes of 700 g each
Sealing temperature:	160°C - 180°C
Weight per unit volume:	1.2g/cm <sup>3</sup>

Item no.	Designation
208907	Hot/liquid/bitumen sealing compound TOK-Melt N2

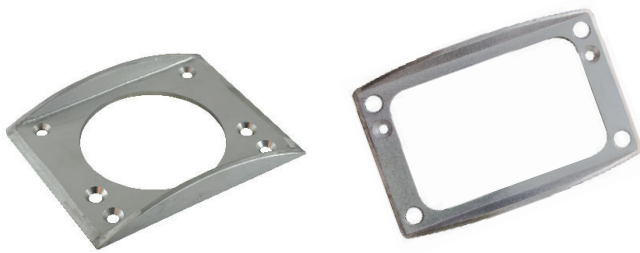

## Guard plate to system MarkLED

In winter, there is often the problem that the snowploughs touch the signal units when entering and exiting the tunnels. That entails that the MarkLED can be sheered off and should be exchanged. Against it we can offer a protective plate. That protects the first MarkLED's at the entrance and exit of the tunnels.

Item no.	Designation
024446	Guard plate V4A to MarkLED, 190×150×24 mm
208653	Guard plate V4A to Surface-mounted adapter MarkLED 245×150×43 mm
024676	Countersunk screw V4A with I-6Kt. without shaft M8×70 mm
024677	Nylon plug Fischer M8-S×50 mm
019180	Nylon plug Fischer Ø6×35 mm, without surrounding
019290	Chipboard screw V4A, Ø5×80/50 mm

For mounting e.g. 860598/860604

## Adhesive and sealant to module MarkLED



The current collector is glued to the base with the help of the sealant and adhesive. Our adhesive is a single-component adhesive that vulcanises itself into an elastic compound as it reacts to the air humidity. It also has no silicone or solvents.

### Technical data

Basis:	MS-Polymer
Cross-linking system:	polymerisation through air humidity
Temperature resistance:	-40° C to +90° C
Processing temperature:	approx. +5° C to +30° C
Color:	pebble gray
Processing:	using a hand spray gun
Packaging:	cartridge of 290 ml

Item no.	Designation
020157	Adhesive and sealant hybrid pebble grey, 290 ml Permafix 1153

Item no.	Designation
211986	Screw A4 - 5.0×80 mm Torx T25 (PU=200)
019180	Fischer nylon dowel Ø6×35mm, without edge

GET IN TOUCH WITH US

News about the assortment and specific solutions can be found on our website:

[www.gifas.ch](http://www.gifas.ch)

We reserve the right to make technical modifications. V 0224



**GIFAS**  
ELECTRIC

GIFAS-ELECTRIC GmbH  
Dietrichstrasse 2  
CH-9424 Rheineck

+41 71 886 44 44  
+41 71 886 44 49  
info@gifas.ch  
www.gifas.ch